

## Novista Riser Timber

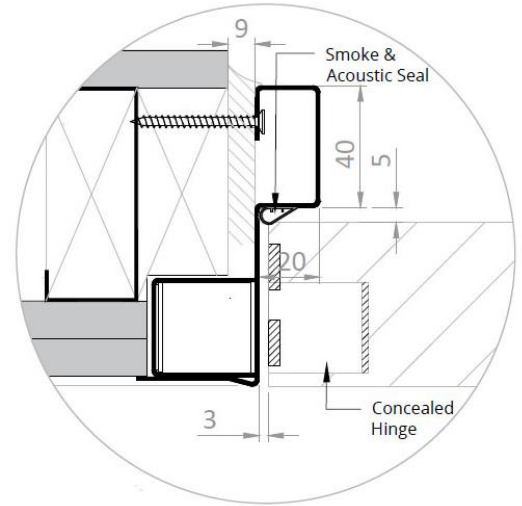

<b>Frame</b>	Concealed/Picture frame design made from 1.2mm steel. 3 or 4 sided frame options
<b>Leaf</b>	Solid core to suit application*
<b>Finish</b>	Primed, veneer or laminated facing
<b>Configurations</b>	Single leaf & double leaf
<b>Leaf Height/width</b>	FD30, up to 2500mm high and 800mm wide leaves* FD60, up to 2420mm high and 850mm wide*
<b>Hinge</b>	Concealed 3D adjustable or standard hinge option
<b>Locking</b>	Deadlock with square key or Europrofile cylinder operation

\*Please consult our technical department

### Performance

**Fire Rating** - FD30/60

**Acoustic Rating** - up to 35dB Rw

**Smoke/Air tested** - To BS6375-1, BSEN1634-3 and to BSEN13501-2

**Thermal Resistance** - Consult technical dept.

