

TIMBER DOORSETS

CONCEALED RISERS

ARCHITECTURAL IRONMONGERY

ACCESS CONTROL

aspex



doorsets
for hotels

www.aspex.co.uk | sales@aspex.co.uk

ABOUT US

Our vision is to offer architectural excellence and this epitomises everything we do..

Aspex offers you the opportunity to add some simplicity to your construction project, as the ultimate source for timber doorsets, risers, architectural ironmongery and access control. Benefit from finding your complete doorset package from one supplier, Aspex, greatly reducing the risk of specification conflict and non-conformance.

Our experienced project consultants can help you make well-informed decisions about your project. Speak to our team about design choices, industry standard or bespoke options, estimating & scheduling, sampling, optimised delivery plans and maintenance tips and more.

Our aim is to support you from design, manufacturing and maintenance, not just supply doorsets.



2006

Aspex was founded on a long-established family historic success and dedication within the architectural ironmongery industry

2010

Introduced access control and integrated systems division. Aspex are Platinum Inspired Business Partners of Salto and work closely with many other manufacturers to secure premises

2012

Introduced supplying timber doorsets working closely with carefully selected door manufacturers

2016

Introduced Novista concealed doorsets, pocket sliding doors and steel and timber risers

2019

Introduced manufacturing of timber doorsets in-house, primarily residential doorsets

2023

Extended factory by 40,000sqft to increase capacity and to bring the production of technical door leaves in-house; manufactured for education, healthcare and commercial sectors

DOORSET DESIGNS

All of our doorsets available in industry-standard and bespoke sizes and finishes. All available in matching sets for consistent interior design look.

All designs, finishes and styles available for:

- Secure FEDs
- Internal doorsets
- Communal doorsets (with glazed screens & access control)

01 FINISHES

Painted



Veneer



Laminated



02 DESIGNS

Panelled



Grooved



Flush



03 STYLES

Contrasting frame



Matching frame



Wall panelling



ENTRANCE DOORSETS

DOOR SPECIFICATION

All fire doors are purpose-made to sizes required, extensive size ranges are validated by an independent tests or authoritative assessment

- Door leaf constructed from a severe duty core tested to DD171, with hardwood lipping's on all 4 sides
- Structural opening size of up to 2400mm high and 1310mm wide
- **DOOR FINISHES:** Primed, Painted, Veneered, Laminated. Matching frames available.
- **FRAME OPTIONS:** Extension linings & architraves. Options - Hardwood, Softwood & MDF frames

PERFORMANCE

- Fire tested to BS 476 part 22
- Fire rating - FD30S (44mm) and FD60S (54mm)
- All fire rated doorsets manufactured under the stringent IFC certification scheme
- Doorsets meet requirements of Approved Doc M for clear opening widths
- Acoustic rating - 29dB, 32dB and 35dB options
- Smoke/ Air tested - compression smoke seals tested in accordance with BS - 9999:2017



EN-SUITE DOORSETS

SPECIFICATION

Manufactured with a solid core

- Door leaf constructed from a severe duty core tested to DD171, with hardwood lipping's on all 4 sides
- Standard sizes or bespoke
- **DOOR FINISHES:** Primed, Painted, Veneered, Laminated. Matching frames available.
- **FRAME OPTIONS:**
Hardwood, Softwood, MDF frames

PERFORMANCE

- NFR



ACCESS CONTROL COMMUNAL

SMART SECURITY

SPECIFICATION

- Access control compatibility with various systems
- Overall thickness 54mm for NFR, FD30 and FD60
- Up to 35dB acoustic rated (with the correct seal arrangement)
- Tested to DD171 and classed as severe duty
- Choice of vision panel design options available

PERFORMANCE

- Fire tested to BS 476 part 22
- All fire rated doorsets manufactured under the stringent BWF Certifire scheme
- Doorsets meet requirements of Approved Doc M for clear opening widths



PANEL DOORS

DESIGN CHOICE

Luxurious panelled design, great look & feel features enhancing your interiors.

- ✓ 2 Panels
- ✓ 3 Panels
- ✓ 4 Panels

FRAME OPTIONS: Primed frame or matching veneered frame. Extension linings & architraves.

FINISHES

- **Primed** - Smooth finish for onsite painting
- **Factory-painted**- Any RAL colour with the option for different colours on each side
- **Veneered** - Natural wood or dyed options to choose from
- **Stained** - Select from a standard range or bespoke to match other elements in the apartment

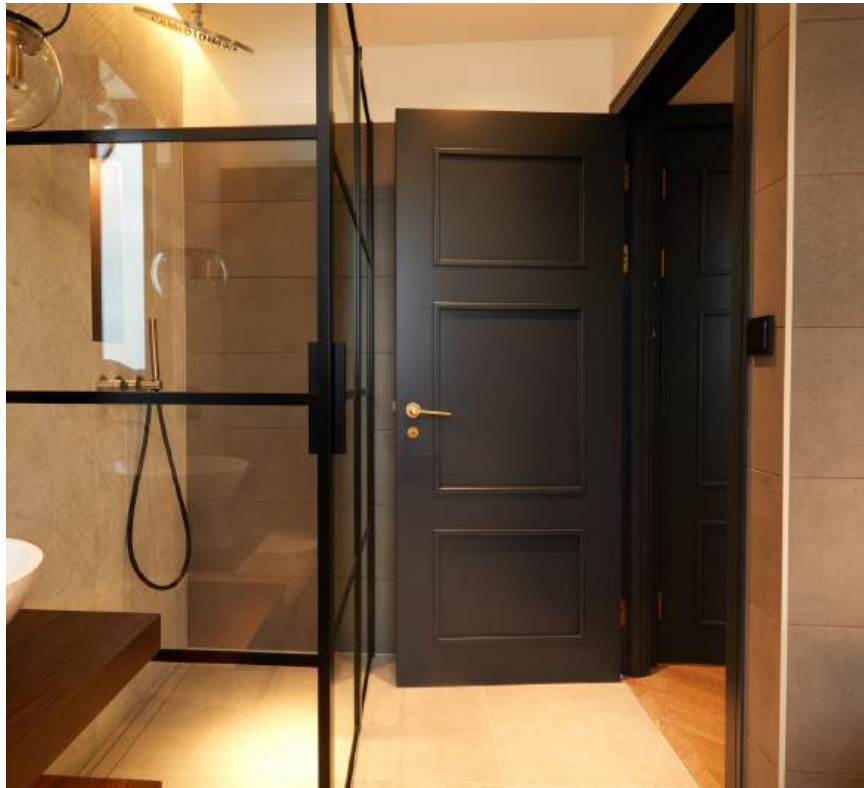

GROOVED DOORS

DESIGN CHOICE

Simply stunning grooved design, attention to detail features enhancing your interiors.

- ✓ Ladder
- ✓ Rectangular
- ✓ Bespoke

Groove options:

- ✓ V shape
- ✓ U shape
- ✓ □ shape

Inlay options:

- ✓ Contrasting Veneer
- ✓ Aluminium
-

FINISHES

- **Primed** - Smooth finish for onsite painting
- **Factory-painted**- Any RAL colour with the option for different colours on each side
- **Veneered** - Natural wood or dyed options to choose from
- **Stained** - Select from a standard range or bespoke to match other elements in the apartment

Ladder design



Rectangular design



Veneered + Grooved



FLUSH DOORS

DESIGN CHOICE

Contemporary, elegant flush entrance and en-suite doors

All timber doors are FSC certified.

- ✓ Factory painted
- ✓ Laminated
- ✓ Veneered
- ✓ Veneered with in-lays



VENEER DOORS

FINISH CHOICE

Real wood veneers allow the beauty of the natural wood grain and tone to be brought to life, creating a finish that preserves its true presence.

- ✓ Matt Lacquer
- ✓ Super-matt Lacquer
- ✓ Natural Veneer Crown or Quarter Cut
- ✓ Engineered Veneers
- ✓ Dyed Veneers
- ✓ Stained Veneers



LAMINATES

FINISH CHOICE

Hard-wearing laminates are ideal for both aesthetic and durability requirements.

- ✓ Laminates are durable and hygienic
- ✓ Ideal choice for high-traffic door applications
- ✓ High-performance surfacing solution

Available in a range of colour and wood texture choices



PAINTED FINISH CHOICE

Popular factory-painted doors allow you to touch-up as needed, enhancing the look & feel easily.

Choose any RAL colour to closely match your interior look. Excellent range of standard and bespoke RAL colours



VENEER *choices*

Choose luxurious veneers finishes - from natural, dyed, smoked and reconstituted finishes.

*Not exhaustive list

Request for more choices - sales@aspex.co.uk

NATURAL VENEERS

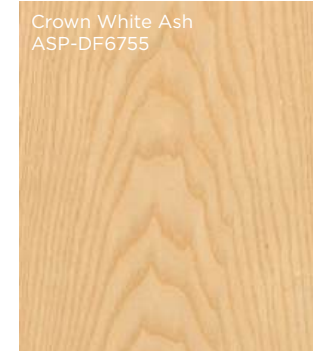
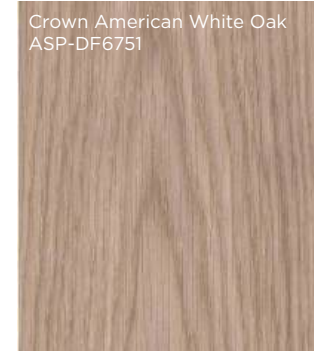
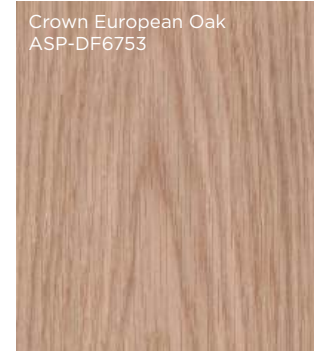
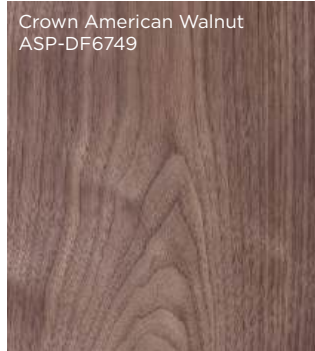

DYED/SMOKED VENEERS

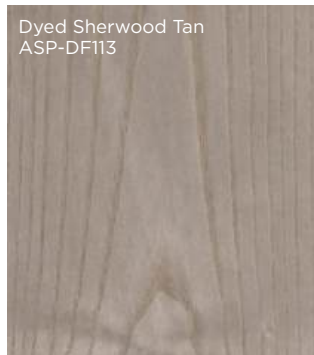

ENGINEERED VENEERS

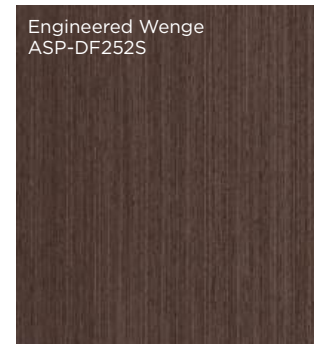
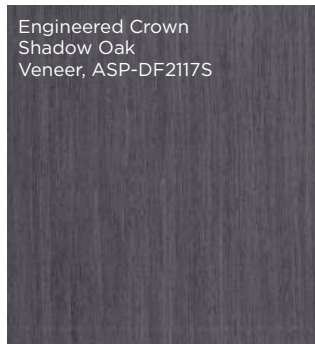

LAMINATE *choices*

Choose beautiful laminate finishes to enhance your interiors. Working with Egger & Formica to offer you high-quality laminates.

*Not exhaustive list

Request for more choices - sales@aspex.co.uk

ESSENTIALS - STANDARD

Light Grey
ASP-EGGU708 ST9

Graphite Grey
ASP-EGGU961 ST7

Black
ASP-EGGU999 ST7

Natural Lancaster Oak
ASP-EGGH3368 ST9

ESSENTIALS - EXTENDED

Brown Warmia Walnut
ASP-EGGH1307 ST19

Brown Tonsberg Oak
ASP-EGGH309 ST12

Vicenza Oak
ASP-EGGH3157 ST12

Beige Grey Lorenzo Oak
ASP-EGGH3146 ST19

Natural Davos Oak
ASP-EGGH3131 ST12

Dark Brown Eucalyptus
ASP-EGGH3043 ST12

Truffle Brown Denver Oak
ASP-EGGH1399 ST10

Natural Hamilton Oak
ASP-EGGH3303 ST10

Sevilla Ash
ASP-EGGH1223 ST19

Natural Sheffield Acacia
ASP-EGGH1242 ST10

Brown Belmont Oak
ASP-EGGH1303 ST12

Lincoln Walnut
ASP-EGGH1714 ST19

RAL choices

Choose any RAL colour to closely match your doorset to complement your interior design. Bespoke colour options available

*Not exhaustive list

Request for more choices - sales@aspex.co.uk

BLUES

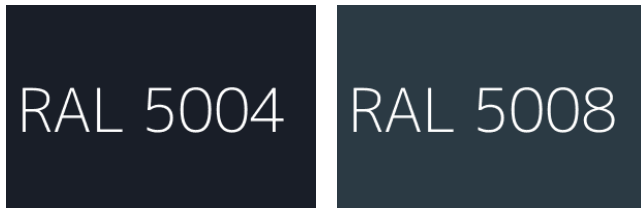

REDS



BLACKS

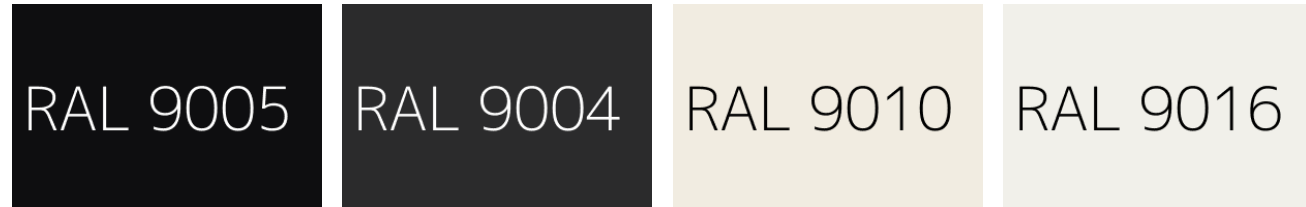

BROWNS

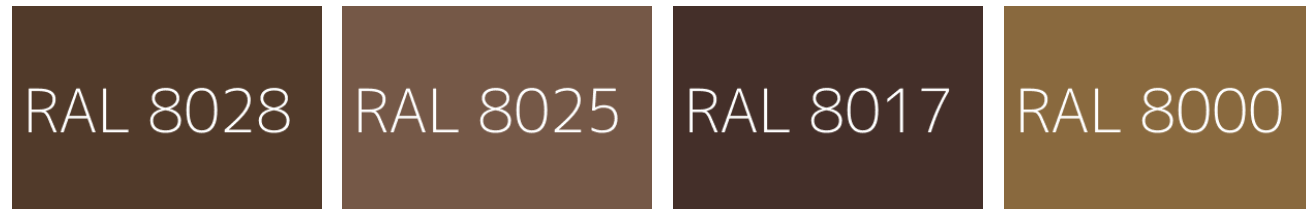

GREYS

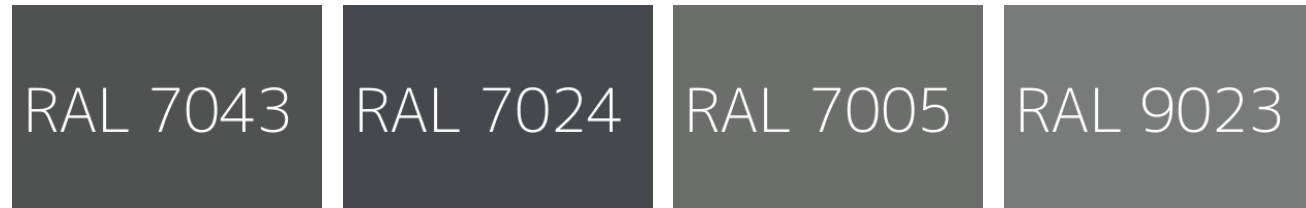

GREENS



NOVISTA STEEL RISERS

FRAME

Concealed/Picture frame design made from 1.2mm steel. 3 or 4 sided frame options

LEAF

Double skin 1.0mm Zintec Steel with glass wool insulated core. 48mm thick

CONFIGURATIONS

Single leaf, double leaf and up to six leaves within one frame

PERFORMANCE

- Fire Rating - FD120(S)
- Acoustic Rating - 41dB Rw (as standard)
- Smoke/Air tested - To BS6375-1, BSEN1634-3 and to BSEN13501-2
- Thermal Resistance - 1.43(m²K)/W

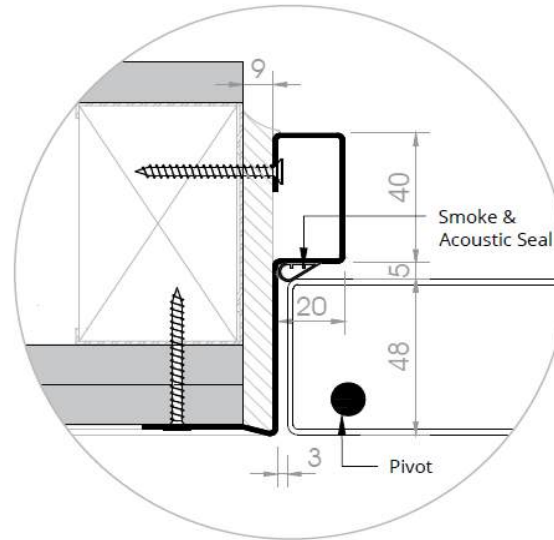

INTU-FRAME OPTION

NOVISTA RISER STEEL

DRY-INTUMESCENT FRAME

Factory-fitted to riser frames, the dry intumescent seal expands behind the frame to seal tolerance gaps up to 15mm in event of fire, taking the place of fire foam. Fire rated to FD120

BI-DIRECTIONAL FIRE-TESTING

In line with current construction trends, Novista Risers are tested from both directions of attack from fire when fitted with intu-frame protection option



FLIP LOCK OPTION

NOVISTA RISER STEEL

CONCEALED LOCK

Flip lock hides chosen lock mechanism behind a flush hinged pocket.

FD60 fire rated and bi-directionally tested

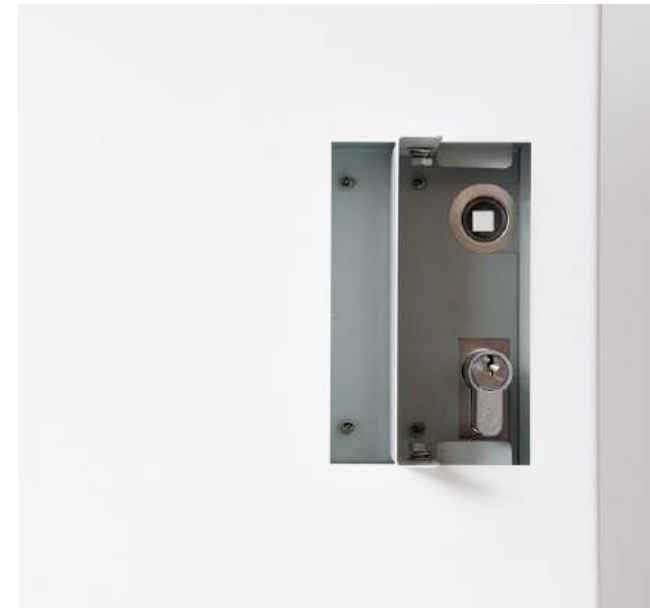
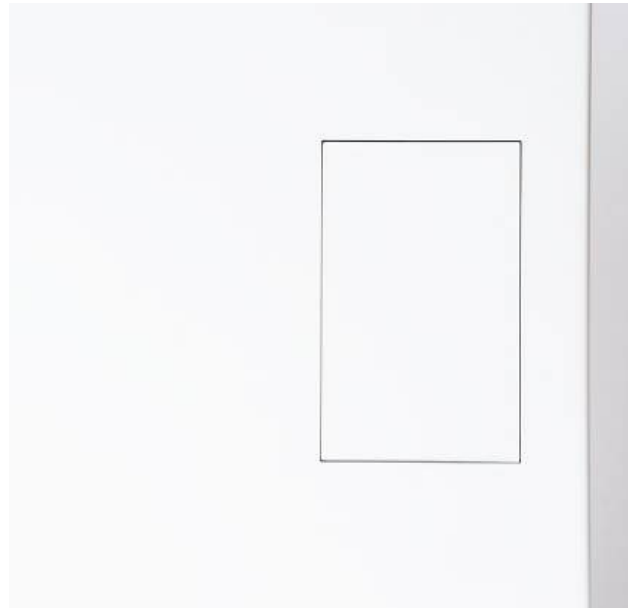

NOVISTA TIMBER RISERS

FRAME

Concealed/Picture frame design made from 1.2mm steel. 3 or 4 sided frame options

LEAF

Solid core to suit application*

FD30, up to 2500mm high and 800mm wide

leaves*FD60, up to 2420mm high and 850mm wide*

CONFIGURATIONS

Single leaf & double leaf

PERFORMANCE

- Fire Rating - FD30/60
- Acoustic Rating - up to 35dB Rw
- Smoke/Air tested - To BS6375-1, BSEN1634-3 and to BSEN13501-2
- Thermal Resistance - Consult technical dept.

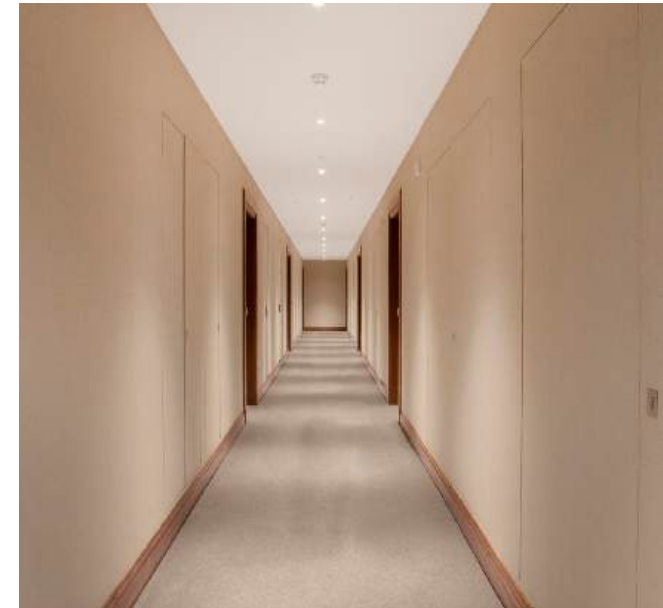
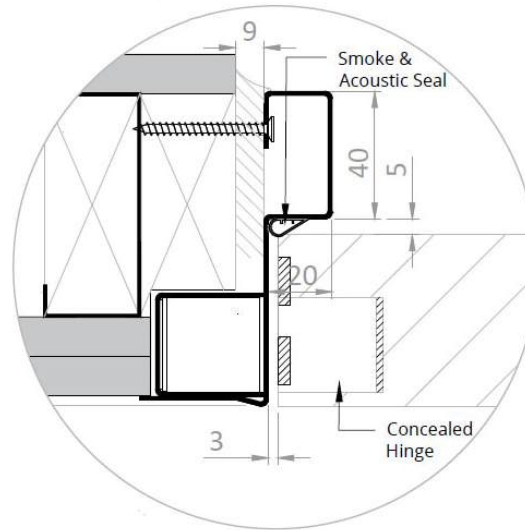

IRONMONGERY

EXCELLENT RANGE

Ultimate solution of architectural ironmongery from...

- ✓ Lever handles
- ✓ Pull handles
- ✓ Escutcheons
- ✓ Turns and releases
- ✓ Hinges
- ✓ Signage
- ✓ Locks & cylinders
- ✓ Door closers
- ✓ Panic Hardware
- ✓ Miscellaneous

Range of finishes...

- ✓ Stainless Steel
- ✓ Satin Stainless Steel
- ✓ Satin Chrome
- ✓ Polished Chrome
- ✓ PVD Bronze

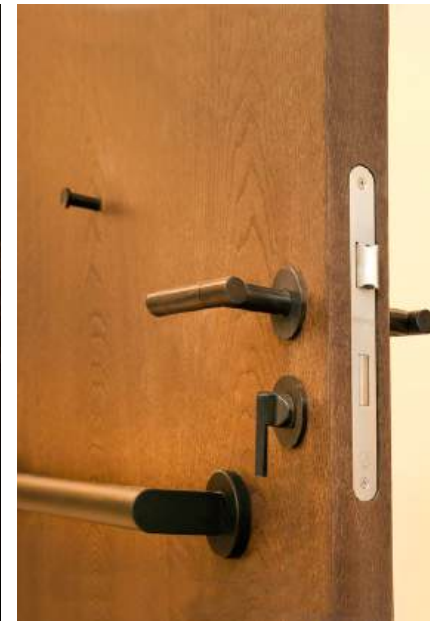

IRONMONGERY

POPULAR CHOICES

LEVER HANDLES

Manufactured from stainless steel
Sprung rose through fixed rose
Spindle fast fixing system prevents levers
from pulling off the doors
Concealed fixings to prevent illegal tampering
Lever fixed to metal inner rose



CONCEALED DOOR CLOSER

A high efficiency, true cam action concealed slide
arm closer. CE marked against EN1154
Included in successful fire test to EN1634
Suitable for use on timber fire doors



DOOR STOP

60031 floor fixed door stop with threaded location
bolt and rubber buffer. Location bolt extends 15mm
into the floor providing very secure fixing
Available in satin/polished stainless steel or
satin anodised aluminium



DOOR STOP

Heavy duty floor mounted door stop.
Concealed fix. Stainless steel material.
Supplied with fixings

IRONMONGERY

POPULAR CHOICES

T BAR PULL HANDLE

Bolt through fixed with M8 machine screws
Suitable for doors up to 54mm thick
Available in satin or polished stainless steel
Dimensions comply with the requirements of
BS8300 and Approved Document M

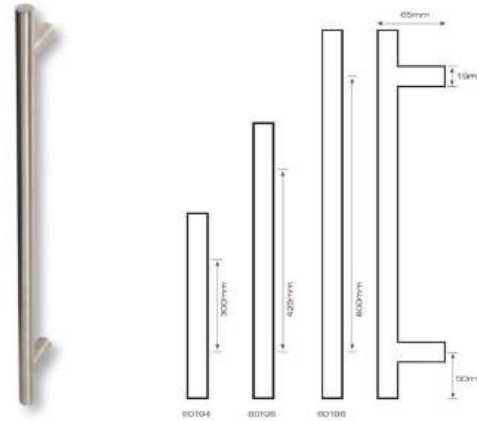

KICK PLATE

Plates of any size can be manufactured
Available in satin/polished stainless steel
or satin anodised aluminium



FIRE SIGNAGE

Available in satin/polished
stainless steel or satin anodised aluminium
Drilled & countersunk for screw fixings
Screen printed



Ælement

SALTO SOLUTION

A hotel experience you need to discover. The minimalistic design of the RFID reader looks stylish and discreet on any door. It also offers the choice of a wide range of designer lever handles and finishes

Reader body made using double layered injection construction

Clear dual colour LED light (green/red) to indicate lock authorisation

Special blink and beep indication when lock is in privacy mode

Ability to enable/disable the acoustic signal

Covers door thicknesses: From 35mm to 125mm





Let's work on specifications together, find us on...



NBS Chorus



NBS Source
PARTNER

FREE SAMPLES

Request for door leave samples & ironmongery sample board to see how well we can match your project requirements. Simply email sales@aspex.co.uk

GET IN TOUCH

www.aspex.co.uk | sales@aspex.co.uk
England office: 0116 278 3506
Scotland office: 01236 720061

aspex